

Style 7 Balustrade

Vaux-Le-Vicomte Baluster combined with the Georgian Rail and Vyne Plinth with Decorated Piers.

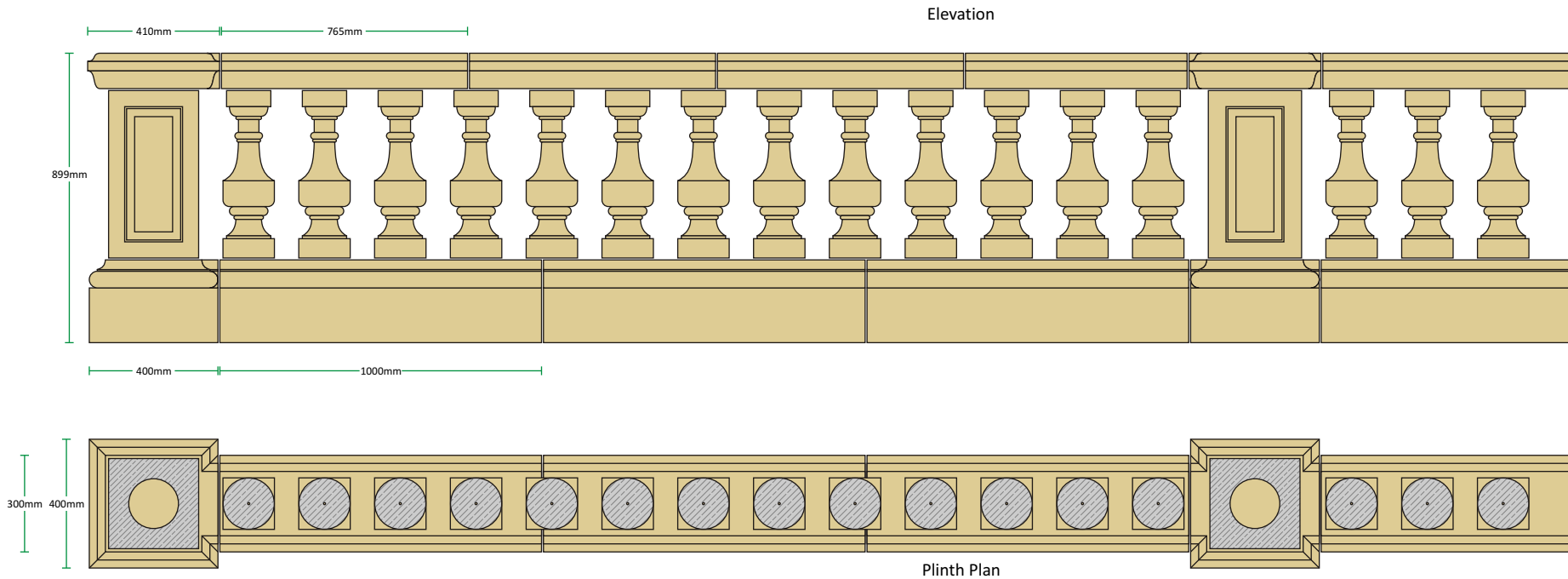

'Style 7' Balustrade		Height	Width	Length	Weight
Description	Code	(mm)	(mm)	(mm)	(Kg)
Vaux-le-Vicomte baluster	BS14A	520	160	160	19
Vaux-le-Vicomte baluster - Sloping*	BS14B	520	140	140	19
Georgian Rail	BS4C	110	260	765	37
Vyne Plinth	BS12D	257	300	1000	113
Georgian Pier Cap - End	BS4E	110	410	410	33
Georgian Pier Cap - Intermediate	BS4F	110	410	410	33
Georgian Pier Cap - Corner	BS4G	110	410	410	33
Vyne Pier Plinth - End	BS12H	257	400	400	60
Vyne Pier Plinth - Intermediate	BS12I	257	400	400	60
Vyne Pier Plinth - Corner	BS12J	257	400	400	60
Vyne Panelled Pier Shaft	BS12L/520	520	280	280	64

* The Sloping Vaux-Le-Vicomte baluster can be made to any angle, please specify the angle required at time of ordering

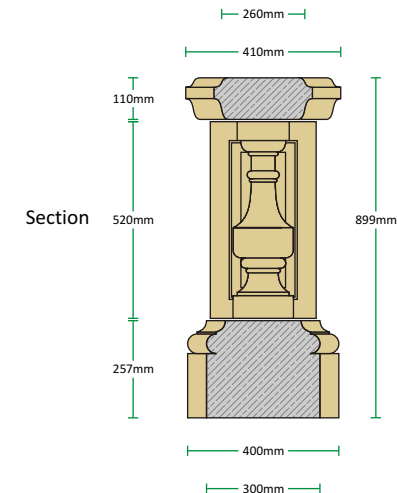

All our balustrade styles feature an optional 135° Pier, please call a member of our technical team with your requirements.