

Style 21 Balustrade

Oxford Baluster combined with the Kensington Rail and Plinth with Panelled Piers.

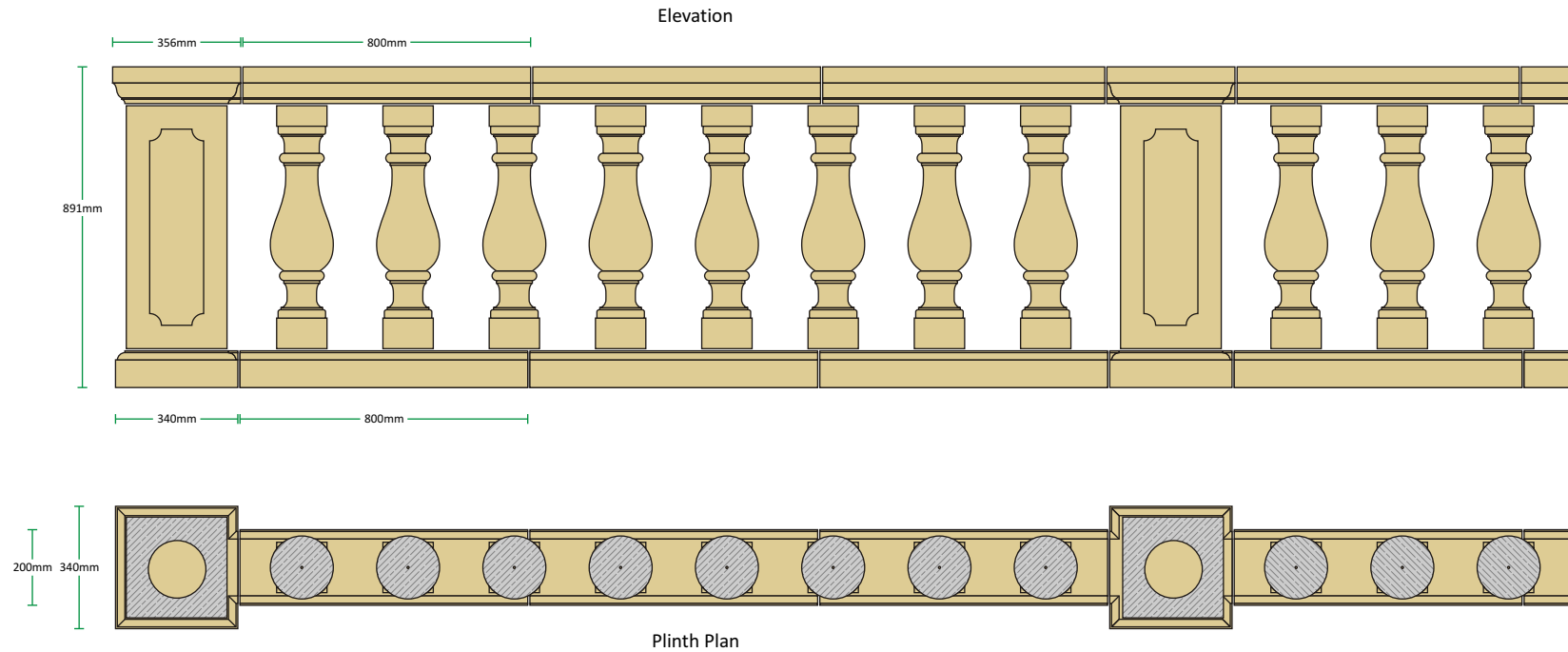

'Style 21' Balustrade		Height	Width	Length	Weight
Description	Code	(mm)	(mm)	(mm)	(Kg)
Oxford baluster	BS9A	675	140	140	26
Oxford baluster - Sloping*	BS9B	675	140	140	26
Kensington Rail	BS7C	102	220	800	32
Kensington Plinth	BS7D	102	200	800	31
Kensington Pier Cap - End	BS7E	102	356	356	24
Kensington Pier Cap - Intermediate	BS7F	102	356	356	24
Kensington Pier Cap - Corner	BS7G	102	356	356	24
Kensington Pier Plinth - End	BS7H	102	340	340	22
Kensington Pier Plinth - Intermediate	BS7I	102	340	340	22
Kensington Pier Plinth - Corner	BS7J	102	340	340	22
Kensington Panelled Pier Shaft	BS7L/675	675	280	280	83

* The Sloping Oxford baluster can be made to any angle, please specify the angle required at time of ordering

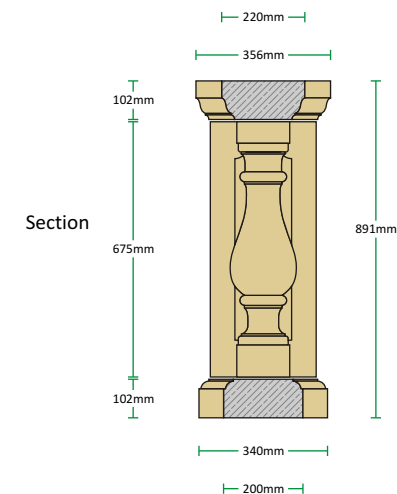

All our balustrade styles feature an optional 135° Pier, please call a member of our technical team with your requirements.